

PRODUCT DATA SHEET

Part Number(s): **NX90SW** Right angle Swivel adapter with self seizing contact

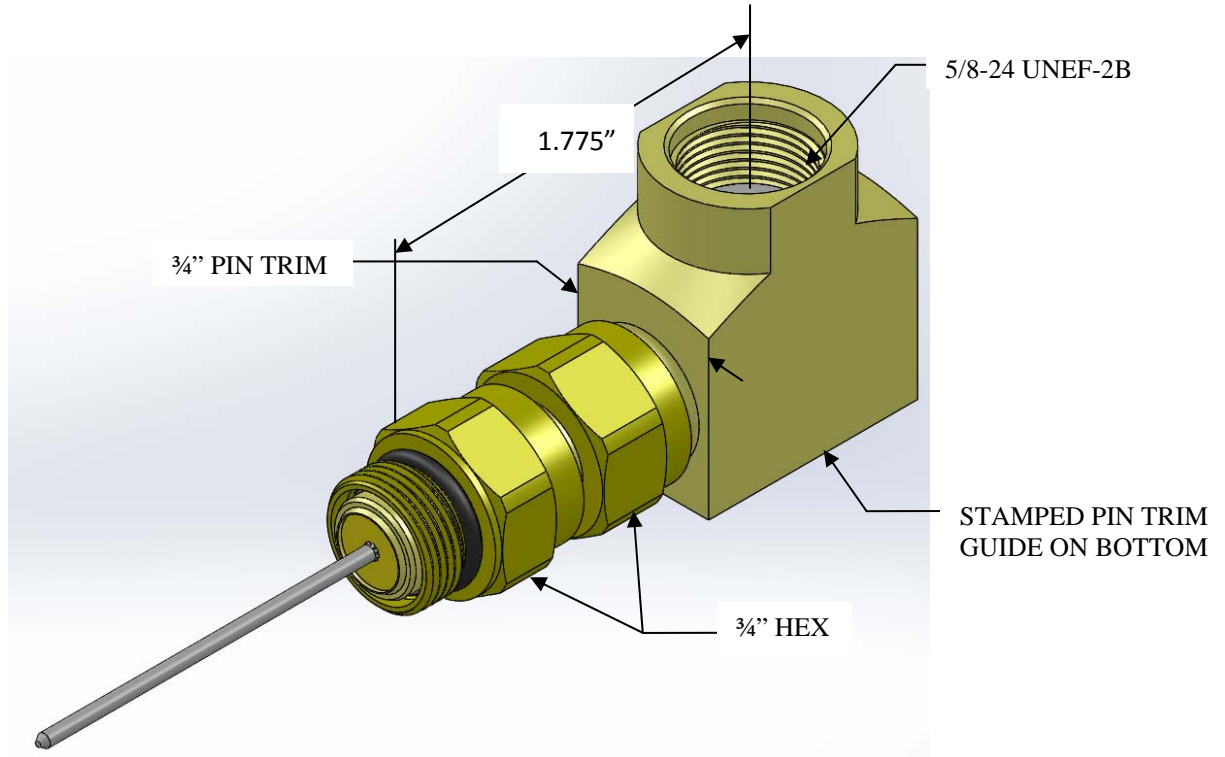

Operation Specification:

Bandwidth	0 MHz to 1 GHz
Impedance	75 Ohms
Return Loss	Better than -30 dB to 1 GHz
Insertion Loss	Less than 0.10 dB to 1 GHz
Operating Voltage Rating	90 Volts (@ 60 Hz continuous AC)
Operating Current Rating	20 Amps (@ 60 Hz continuous AC)
Operating Temperature Range	-40° to +140° F

Tooling Requirements:

- Two (2) 3/4" wrenches
- Suitable wrenches for installing pin connector
- Cutters for pin of connector

INSTALLATION INSTRUCTIONS

NX90SW

1. Loosen the equipment seizure screws.
2. Measure and trim the pin of the Right Angle Adapter to the equipment manufacturer specification.
3. Trim the pin of the connector to $\frac{3}{4}$ ". Use the width of the Right Angle Adapter as a pin trim guide or the TRIM reference stamped on the bottom of the part.
4. Hand tighten the connector into the Right Angle Adapter. Wrench tighten an additional $\frac{1}{8}$ to $\frac{1}{4}$ turns while holding the adapter with another wrench.
5. Hand tighten the port nut of the Right Angle Adapter into the equipment housing then tighten an additional $\frac{1}{8}$ to $\frac{1}{4}$ turn with a wrench.
6. Hand tighten the jam nut of the Right Angle Adapter to the port nut while holding the adapter stationary, then further tighten the jam nut $\frac{1}{8}$ to $\frac{1}{4}$ turn with a wrench.
7. Tighten the seizure screw within the equipment housing according to the manufacturer's specification.

