

**PRODUCT DATA SHEET**

Part Number(s): **NX 90 SW Extension Series** Right angle swivel extension adapter with self seizing contact

Part Number	A (inches)
NX 90 1.5 SW	3.275
NX 90 3 SW	4.775
NX 90 4.5 SW	6.275
NX 90 6 SW	7.775

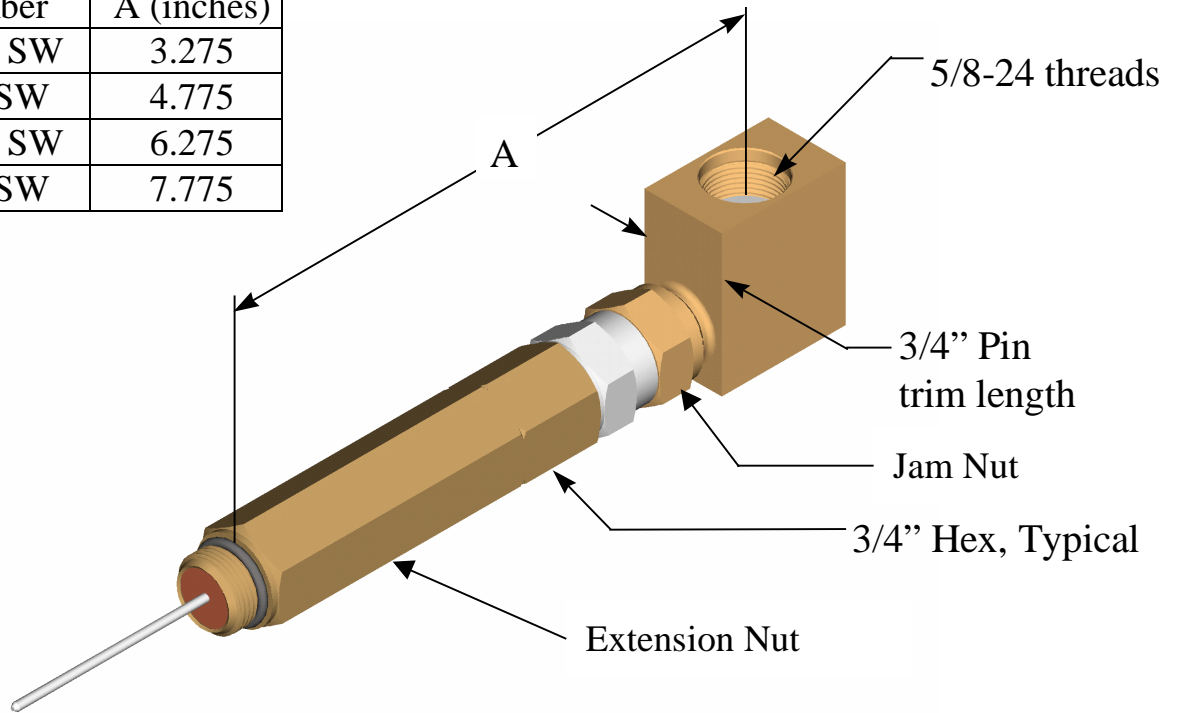

**Operation Specification:**

Bandwidth	0 MHz to 1 GHz
Impedance	75 Ohms
Return Loss	Better than -30 dB to 1 GHz
Insertion Loss	Less than 0.10 dB to 1 GHz
Operating Voltage Rating	90 Volts (@ 60 Hz continuous AC)
Operating Current Rating	20 Amps (@ 60 Hz continuous AC)
Operating Temperature Range	-40° to +140° F

**Tooling Requirements**

- Two (2) ¾” wrenches
- Suitable wrenches for installing pin connector
- Cutters for pin of connector

## INSTALLATION INSTRUCTIONS

### NX 90 SW Extension Series

1. Loosen the equipment seizure screws.
2. Measure and trim the pin of the Right Angle Adapter to the equipment manufacturer's specification.
3. Trim the pin of the connector to  $\frac{3}{4}$ ". Use the width of the Right Angle Adapter as a pin trim guide.
4. Hand tighten the connector into the Right Angle Adapter then wrench tighten an additional  $\frac{1}{8}$  to  $\frac{1}{4}$  turns while holding the adapter with another wrench.
5. Hand tighten the extension nut of the Adapter into the equipment housing then tighten an additional  $\frac{1}{8}$  to  $\frac{1}{4}$  turn with a wrench.
6. Hand tighten the jam nut of the Right Angle Adapter to the extension nut while holding the adapter stationary, then further tighten the jam nut  $\frac{1}{8}$  to  $\frac{1}{4}$  turn with a wrench.
7. Tighten the seizure screw within the equipment housing according to the manufacturer's specification.

